

# Stand-on stacker truck 1.6 ton

## BT staxio

*S-series*

SSE160D

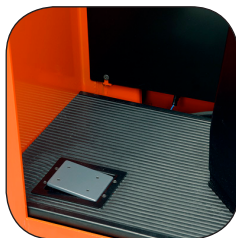
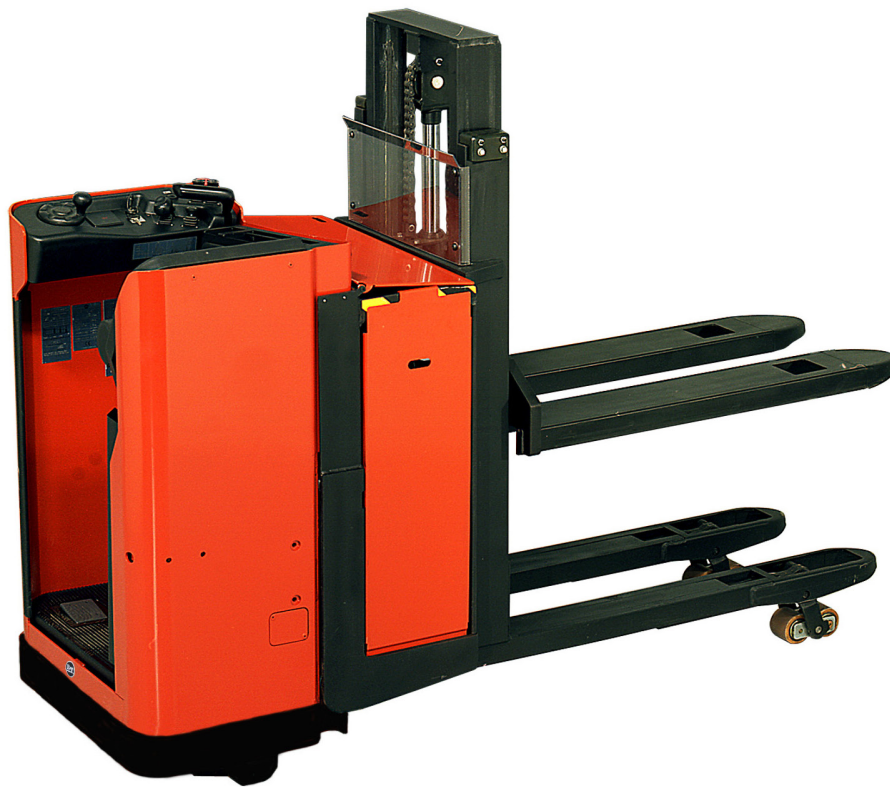

# Stand-on stacker truck

Specifications					SSE160D
Identification	1.1	Manufacturer			BT
	1.2	Model			SSE160D
	1.3	Drive			Electric
	1.4	Operator type			Stand on
	1.5	Load capacity/rated load/support arm lift	Q	kg	1200/1600
	1.6	Load centre	c	mm	600
	1.8	Load distance, front axle to front face, fork raised/lowered	x	mm	892
Weight	2.1	Service weight without battery		kg	901
	2.2	Axle load, with load, drive/castor/support arm wheels		kg	1295/1300
	2.3	Axle load, without load, drive/castor/support arm wheels		kg	1053/342
Wheels	3.1	Drive/castor/fork wheel			Vulkollan
	3.2	Wheel size, front		mm	Ø 80
	3.3	Wheel size, rear		mm	Ø 250
Dimensions	4.2	Height, mast lowered	$h_1$	mm	1330
	4.3	Free lift	$h_2$	mm	160
	4.4	Lift	$h_3$	mm	1585
		Lift height	$h_{23}$	mm	1675
	4.5	Height, mast extended	$h_4$	mm	2090
	4.6	Initial lift	$h_5$	mm	120
	4.8	Instep height	$h_7$	mm	254
	4.15	Height, fork lowered	$h_{13}$	mm	90
	4.19	Overall length	$l_1$	mm	2229
	4.20	Length to face of forks	$l_2$	mm	1079
	4.21	Overall width	$b_1$	mm	770
	4.22	Fork dimensions	s/e/l	mm	60/180/1150
	4.25	Width over forks	$b_5$	mm	570
	4.32	Ground clearance, under mast, min.-max.	$m_1$	mm	17-137
4.35	Turning radius	$W_a$	mm	1992	
Performance data	5.1	Travel speed, with/without load		km/h	8,0/10,0
	5.2	Lift speed, with/without load		m/s	0,11/0,18
	5.3	lowering speed, with/without load		m/s	0,15/0,13
	5.8	Max. gradeability, with/without load <sup>1)</sup>		%	8/10
	5.10	Service brake			Electromagnetic
Electric motor	6.1	Drive motor rating S2 60 min		kW	2,2
	6.2	Lift motor rating at S3 5%		kW	2,2
	6.4	Battery voltage/nominal capacity $K_5$		V/Ah	48/450
	6.5	Battery weight, min./max.		kg	375-420
Others	8.1	Type of drive control			Stepless

1) Measure according to company standard.

All data are based on table configuration. Other configurations may give other values.

Truck performance and dimensions are nominal and subject to tolerances.

BT products and specifications are subject to change without notice.

# Mast dimensions

# BT staxIO

SSE160D			Duplex Tele	
$h_{23}$	Lift height	mm	1675	
$h_1$	Height, mast lowered	mm	1330	
$h_2$	Free lift	mm	160	
$h_4$	Height, mast extended	mm	2090	

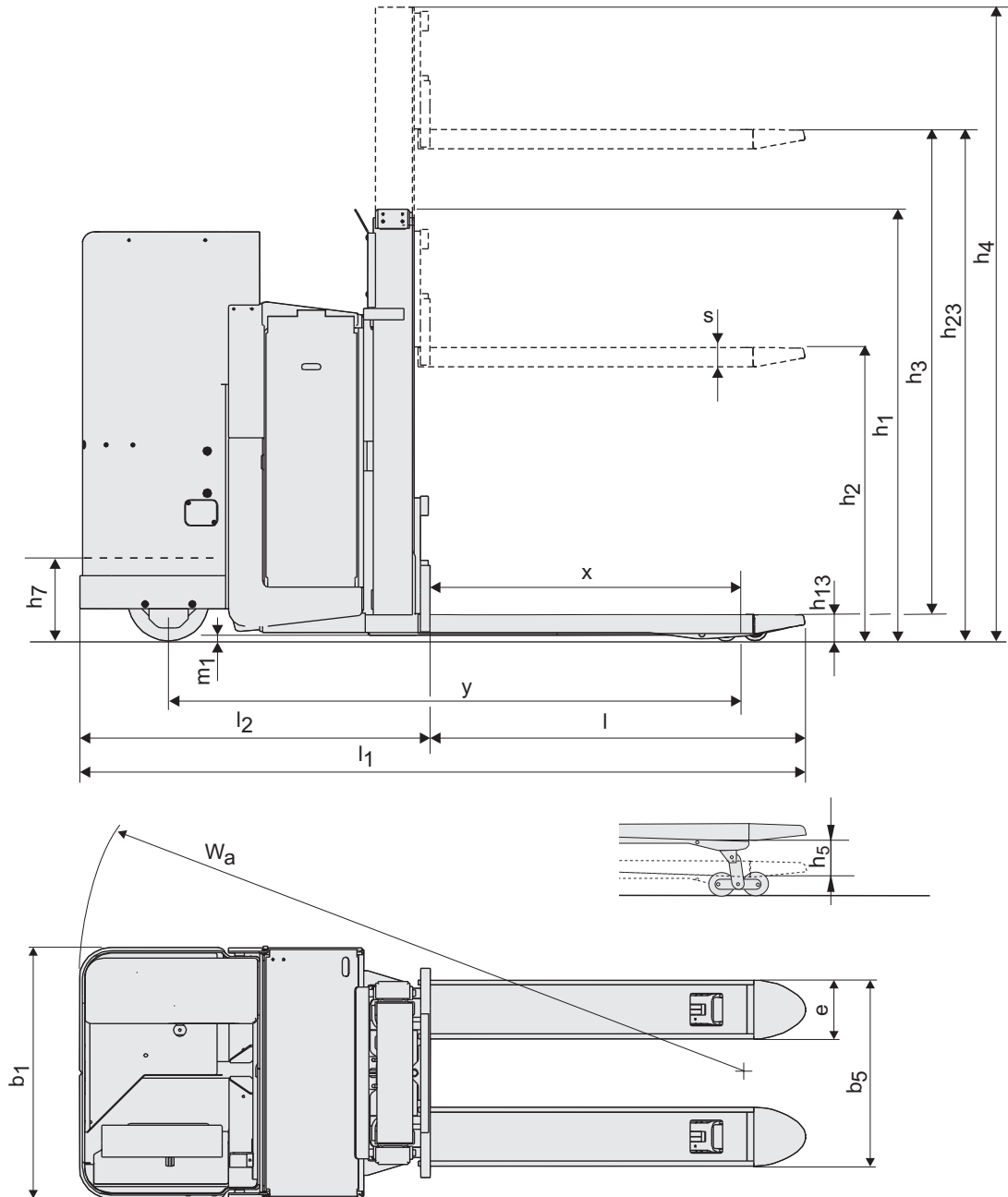

---

## Truck features:

- Double pallet handling
- Elevating support arms
- Fingertip controls
- Electronic steering
- Automatic deceleration
- Driver detection system
- Adjustable backrest
- Easy access for maintenance
- Sideways battery change

